

CARACTERÍSTICAS TÉCNICAS

COLORES

ENCIMERA SUPERIOR - CRISTAL

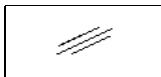

BLANCO, CRISTAL
TEMPLADO



CUERPO

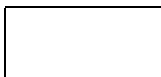

67 BLANCO
PASTEL



FRONTAL - METAL



M015 BLANCO
SEMI-MATE



FRONTAL - PLEXIGLASS

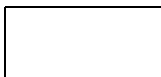

PLEXIGLASS
BLANCO



CARACTERÍSTICAS TÉCNICAS

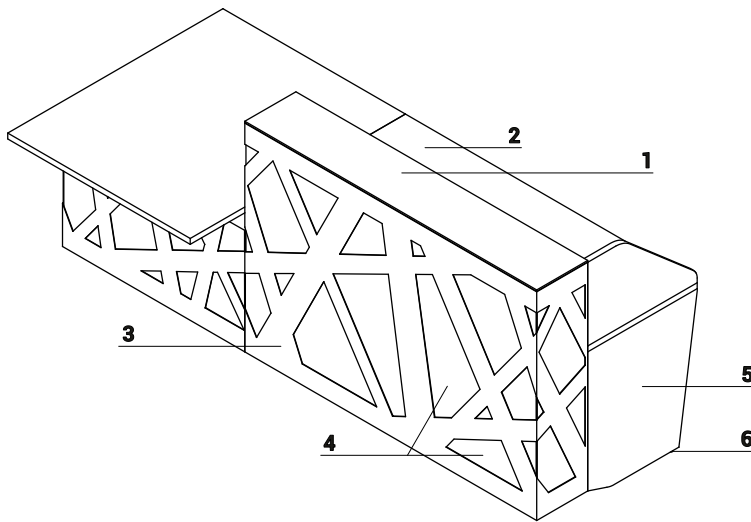

- 1. Encimera - Cristal Optiwhite templado, 8mm - parte inferior lacada
- 2. Encimera - MFC 28mm, cantos PVC - con o sin rebajes pasacables
- 3. Frontal - acero lacado y plexiglas
- 4. Fuente - sistema LED RGBW, mando a distancia
- 5. Panel lateral bajo - MFC 28mm, cantos PVC
- 6. Nivelación - 0-5mm

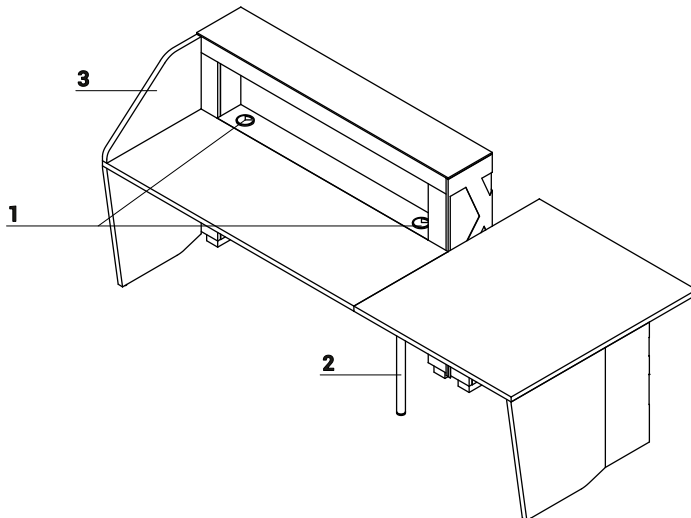

- 1. Tapones pasacables - Ø80mm
- 2. Pata de apoyo NE41 - necesaria en la unión de encimeras
- 3. Panel transversal - MFC 28mm, cantos PVC

DIMENSIONES

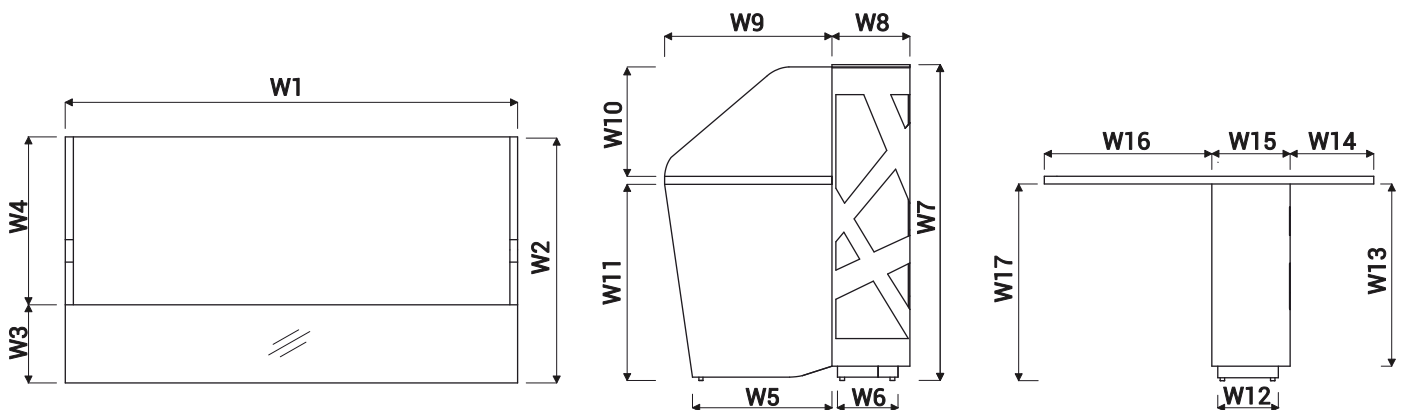

W1 - 1600mm | W2 - 880mm | W3 - 280mm | W4 - 600mm | W5 - 500mm | W6 - 217mm | W7 - 1146mm | W8 - 280mm | W9 - 600mm | W10 - 397mm | W11 - 712mm | W12 - 217mm | W13 - 660mm | W14 - 300mm | W15 - 280mm | W16 - 600mm | W17 - 712mm

SISTEMAS DE MOSTRADORES DE RECEPCIÓN

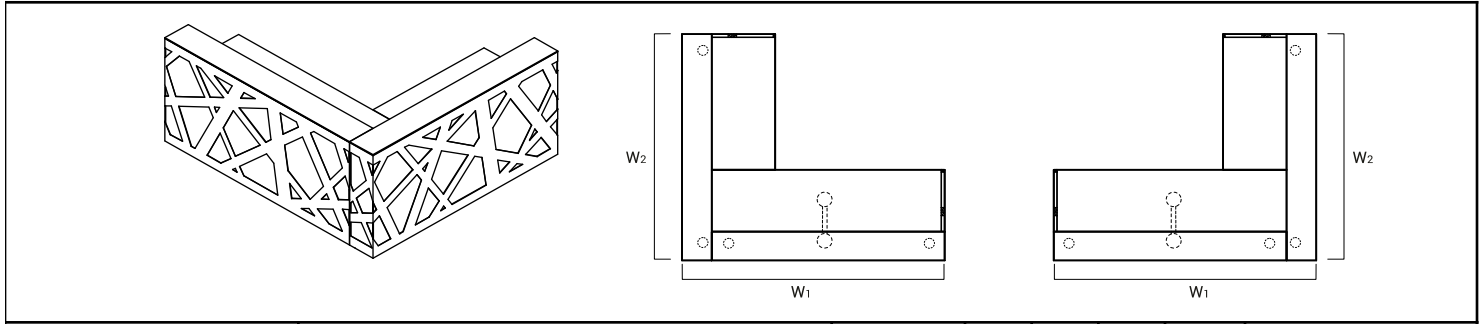

REFERENCIA	DIMENSIONES [mm]						kg	m3	pcs		COMPONENTES
	W ₁	W ₂	D ₁	D ₂	H						
LZG44	2480	2200	-	-	1146		276.2	3.224	14		LZN51+LZB22+2xLZG22+LZB22M+NL41

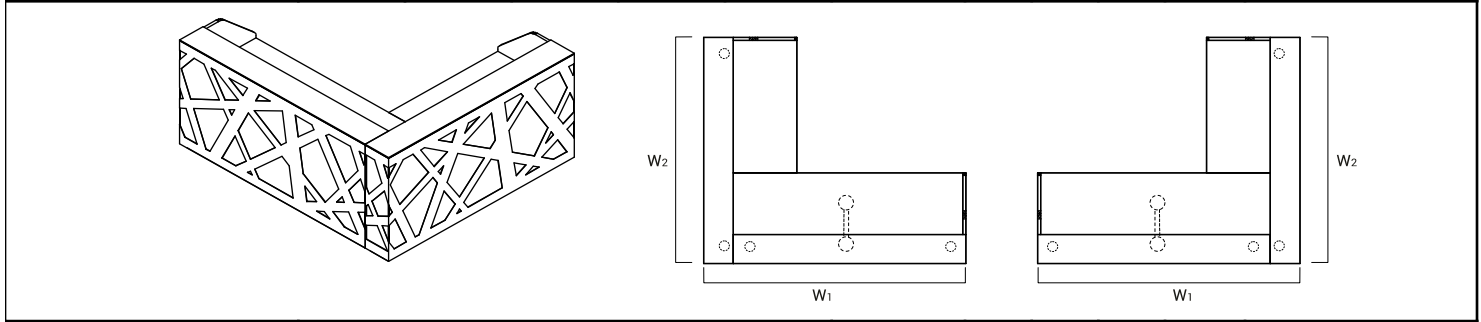

REFERENCIA	DIMENSIONES [mm]						kg	m3	pcs		COMPONENTES
	W ₁	W ₂	D ₁	D ₂	H						
LZG45	2480	2200			1146		283.2	3.243	15		LZN51+LZK01+2xLZG22+LZB22+LZB22M+NL41

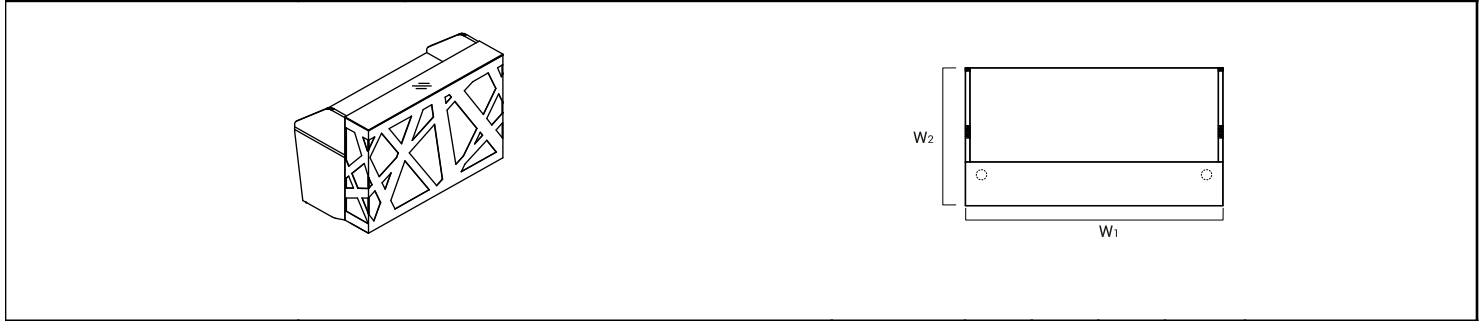

REFERENCIA	DIMENSIONES [mm]						kg	m3	pcs		COMPONENTES
	W ₁	W ₂	D ₁	D ₂	H						
LZG34	1600	880			1146		126.9	1.245	7		LZN51+LZK01+LZG16+LZB16
LZG46	2200	880			1146		156.9	1.690	8		LZN51+LZK01+LZG22+LZB22

DESCRIPCIÓN:

- PESO NETO

- VOLUMEN

- NÚMERO DE PAQUETES

SISTEMAS DE MOSTRADORES DE RECEPCIÓN

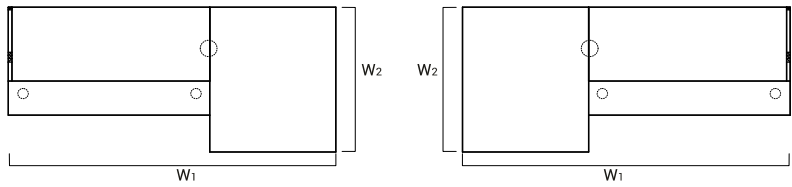
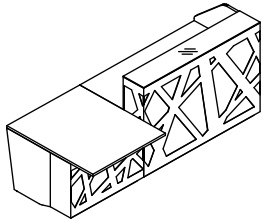

REFERENCIA	DIMENSIONES [mm]						kg	m3	pcs	COMPONENTES
	W ₁	W ₂	D ₁	D ₂	H					
LZG50	2600	1180			1146		208.4	1.798	11	LZN51+LZG10+LZG16+LZB16 +LZK01+NE41L
LZG51	3200	1180			1146		238.4	2.242	12	LZN51+LZG10+LZG22+LZB22 +LZK01+NE41L

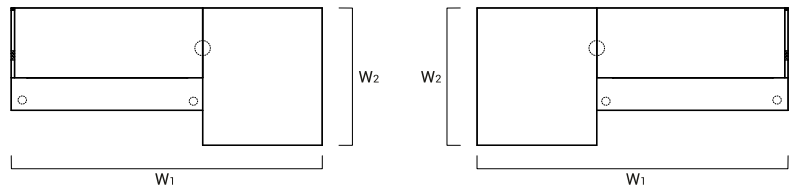
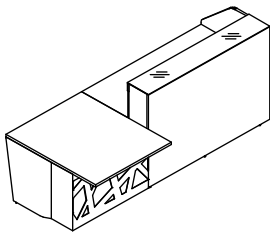

REFERENCIA	DIMENSIONES [mm]						kg	m3	pcs	COMPONENTES
	W ₁	W ₂	D ₁	D ₂	H					
LZG56	2600	1180			1146		210.4	1.798	11	LZG10+LZG16M+LZB16+LZN51 +LZK01+NE41L

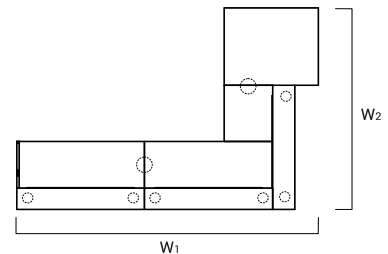
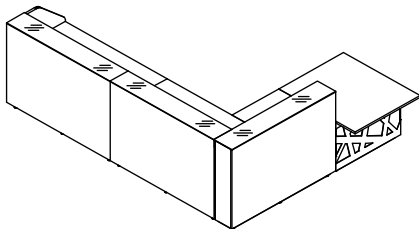

REFERENCIA	DIMENSIONES [mm]						kg	m3	pcs	COMPONENTES
	W ₁	W ₂	D ₁	D ₂	H					
LZG57	3200	2880			1146		419.2	4.153	23	LZN51+LZG10+LZB16M+2xLZB16 +3xLZG16M+LZK01+2xNE41L

DESCRIPCIÓN:

- PESO NETO

- VOLUMEN

- NÚMERO DE PAQUETES

SISTEMAS DE MOSTRADORES DE RECEPCIÓN

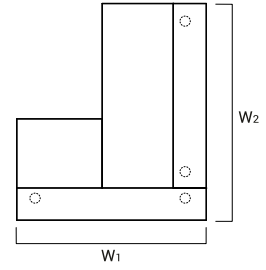
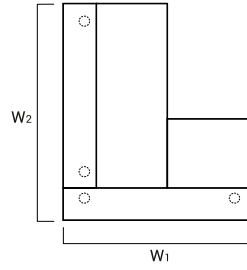
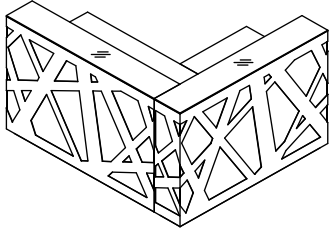

REFERENCIA	DIMENSIONES [mm]						kg	m3	pcs		COMPONENTES
	W ₁	W ₂	D ₁	D ₂	H						
LZG32	1600	1880			1146		217.5	2.386	12		LZB16M+2xLZG16+LZB16+LZN51

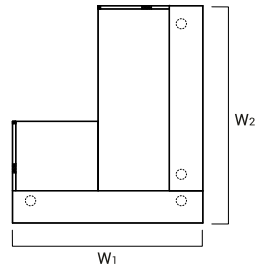
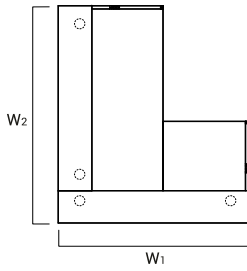
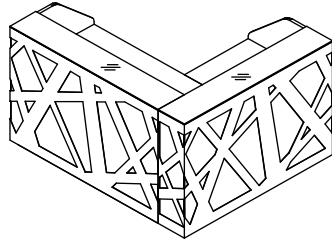

REFERENCIA	DIMENSIONES [mm]						kg	m3	pcs		COMPONENTES
	W ₁	W ₂	D ₁	D ₂	H						
LZG35	1600	1880			1146		224.5	2.405	13		LZB16M+2xLZG16+LZB16+LZN51+LZK01

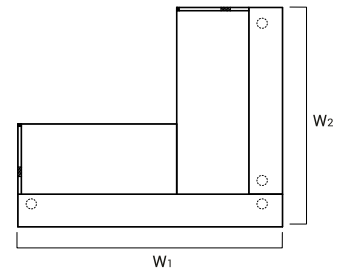
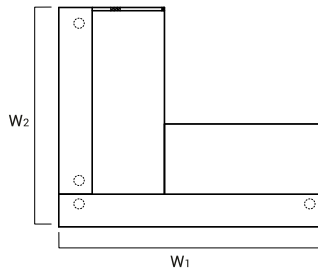
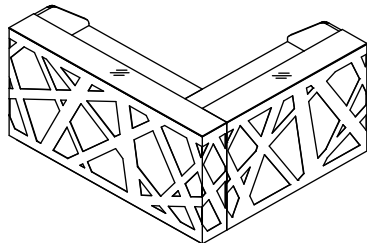

REFERENCIA	DIMENSIONES [mm]						kg	m3	pcs		COMPONENTES
	W ₁	W ₂	D ₁	D ₂	H						
LZG36	2200	1880			1146		252.5	2.799	13		LZN51+LZK01+LZB22+LZG22+LZB16M+LZG16

DESCRIPCIÓN:

- PESO NETO

- VOLUMEN

- NÚMERO DE PAQUETES

SISTEMAS DE MOSTRADORES DE RECEPCIÓN

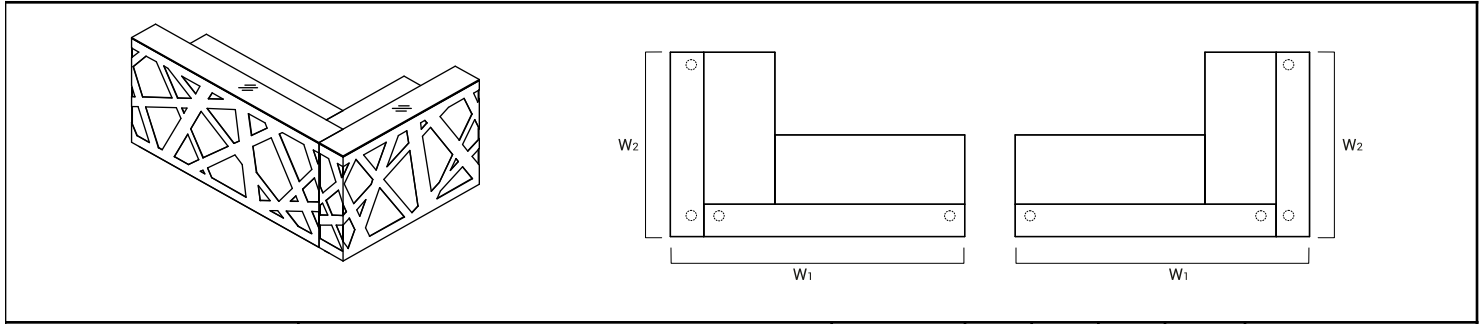

REFERENCIA	DIMENSIONES [mm]						kg	m3	pcs	COMPONENTES
	W ₁	W ₂	D ₁	D ₂	H					
LZG38	2480	1600			1146		245.5	2.779	12	LZN51+LZB16+LZG22+LZB22M+LZG16

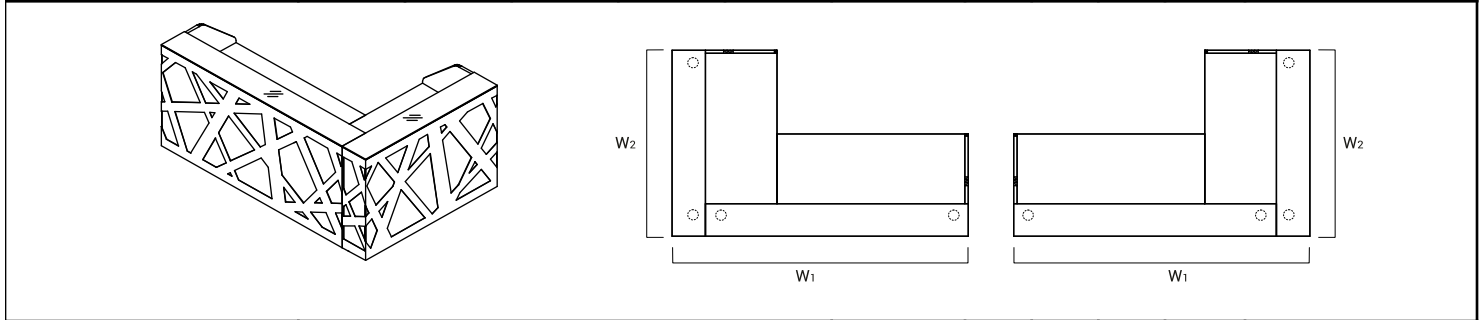

REFERENCIA	DIMENSIONES [mm]						kg	m3	pcs	COMPONENTES
	W ₁	W ₂	D ₁	D ₂	H					
LZG40	2480	1600			1146		252.5	2.799	13	LZN51+LZK01+LZB16+LZG22+LZB22M+LZG16

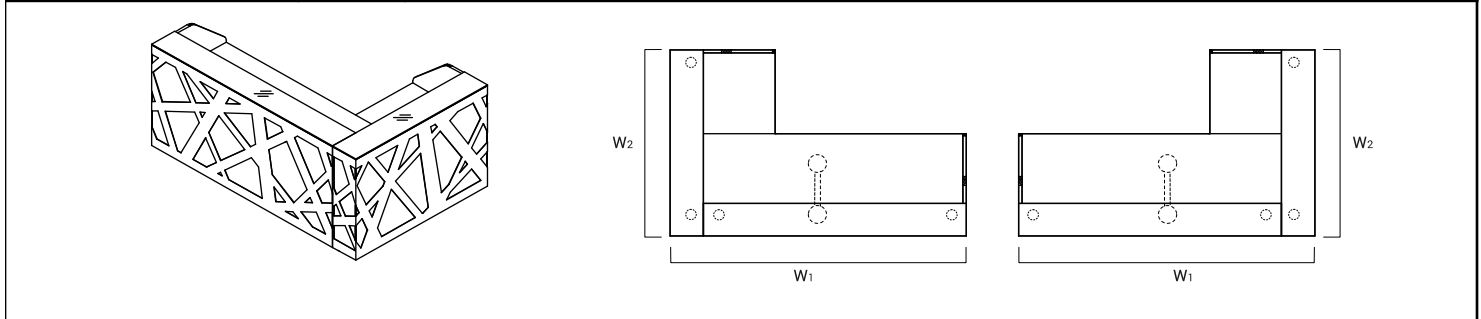

REFERENCIA	DIMENSIONES [mm]						kg	m3	pcs	COMPONENTES
	W ₁	W ₂	D ₁	D ₂	H					
LZG42	2480	1600			1146		252.4	2.849	11	LZN51+LZK01+LZB22+LZG22+LZB16M+LZG16+NL41

DESCRIPCIÓN:

- PESO NETO

- VOLUMEN

- NÚMERO DE PAQUETES

SISTEMAS DE MOSTRADORES DE RECEPCIÓN

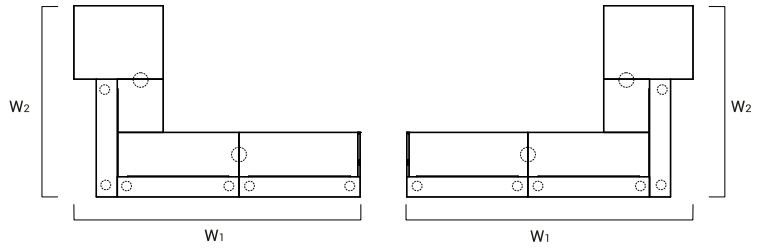
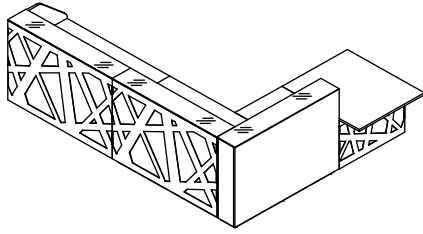

REFERENCIA	DIMENSIONES [mm]						kg	m3	pcs		COMPONENTES
	W ₁	W ₂	D ₁	D ₂	H						
LZG58	3808	2880			1146		415.2	4.153	23		LZN51+LZK01+2xLZB16+2xLZG16 +LZG16M+LZB16M+LZG10N +2xNF41L

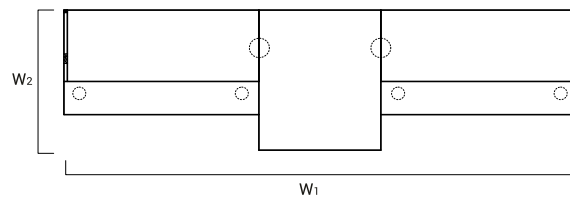
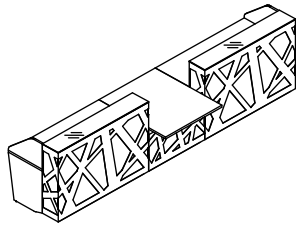

REFERENCIA	DIMENSIONES [mm]						kg	m3	pcs		COMPONENTES
	W ₁	W ₂	D ₁	D ₂	H						
LZG52	4200	1180			1146		314.8	2.991	17		LZN51+LZK01+LZB16+LZG16 +LZG10+LZG16+LZB16+2xNE41L
LZG53	4800	1180			1146		344.8	3.435	18		LZN51+LZK01+LZB16+LZG16 +LZG10+LZG22+LZB22+2xNE41L
LZG54	5400	1180			1146		374.8	3.880	19		LZN51+LZK01+LZB22+LZG22 +LZG10+LZG22+LZB22+2xNE41L

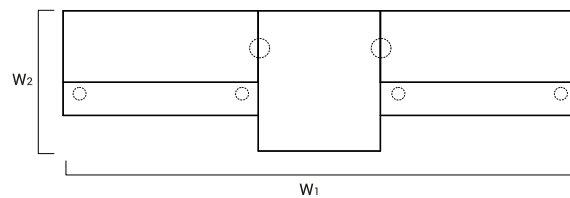
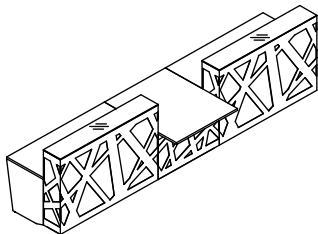

REFERENCIA	DIMENSIONES [mm]						kg	m3	pcs		COMPONENTES
	W ₁	W ₂	D ₁	D ₂	H						
LZG55	4200	1180			1146		307.8	2.971	16		LZN51+LZB16+2xLZG16+LZG10 +LZB16+2xNE41L

DESCRIPCIÓN:

- PESO NETO

- VOLUMEN

- NÚMERO DE PAQUETES

SISTEMAS DE MOSTRADORES DE RECEPCIÓN

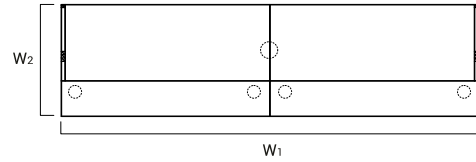
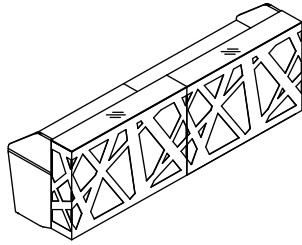

REFERENCIA	DIMENSIONES [mm]						kg	m3	pcs	COMPONENTES
	W ₁	W ₂	D ₁	D ₂	H					
LZG60	3200	880			1146		233.3	2.438	13	LZN51+LZK01+LZB16+LZG16 +LZB16+LZG16+NE41L
LZG61	3800	880			1146		263.3	2.882	14	LZN51+LZK01+LZB16+LZG16 +LZB22+LZG22+NE41L
LZG62	4400	880			1146		293.3	3.327	15	LZN51+LZK01+LZB22+LZG22 +LZB22+LZG22+NE41L

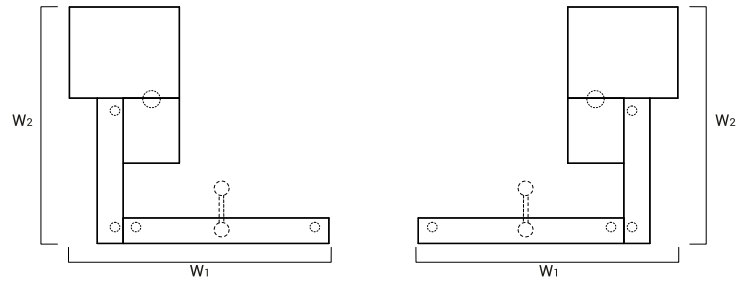
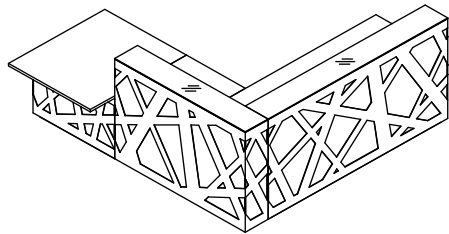

REFERENCIA	DIMENSIONES [mm]						kg	m3	pcs	COMPONENTES
	W ₁	W ₂	D ₁	D ₂	H					
LZG64	2600	2780			1146		328.3	3.383	16	LZN51+LZB22+LZG22+LZG16 +LZB16M+LZG10+NL41+NE41L

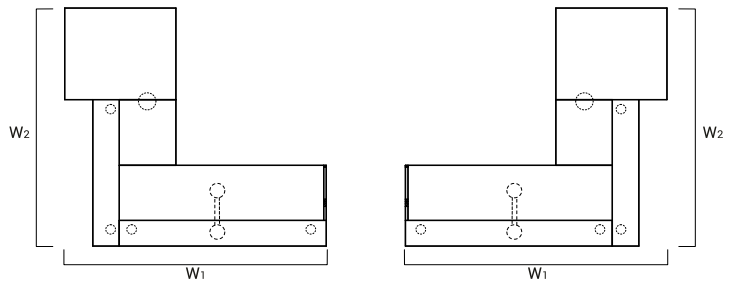
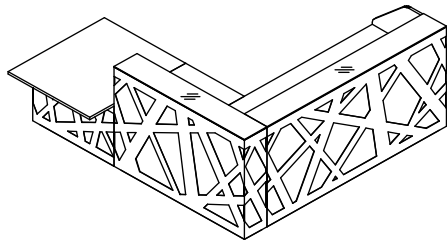

LZN51+LZK01+LZB22+LZG22+LZG16+LZG16M+LZG10+NL41+NE41



REFERENCIA	DIMENSIONES [mm]						kg	m3	pcs	COMPONENTES
	W ₁	W ₂	D ₁	D ₂	H					
LZG63	2600	2780			1146		335.3	3.402	17	LZN51+LZK01+LZB22+LZG22 +LZG16+LZG16M+LZG10+NL41 +NE41L

DESCRIPCIÓN:







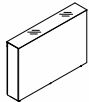
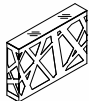
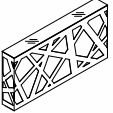

- PESO NETO

- VOLUMEN

- NÚMERO DE PAQUETES

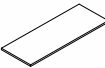
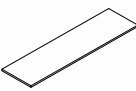
ILUSTRACIÓN DE PRODUCTO	DIMENSIONES [mm]			REFERENCIA						COMPONENTES
	LARGO	PROFUNDIDAD	ALTURA			kg	m3	pcs		

ELEMENTOS DE COMPOSICIÓN

	1600	280	1146	LZG16M		88.5	1.143	2		
	1600	280	1146	LZG16		86.5	1.143	2		
	2200	280	1146	LZG22		107.5	1.523	2		
	1000	1180	740	LZG10		80.0	0.551	3		
	720	600	28	LZB16M		10.4	0.017	3		
	1320	600	28	LZB22M		18.1	0.031	4		
	1600	600	28	LZB16		18.4	0.049	3		
	2200	600	28	LZB22		25.4	0.050	3		¡uso de pata de apoyo NL41 en mitad del tablero recomendado!
	600	28	397	LZK01		7.0	0.020	1		
	600	28	712	LZN51		15.0	0.035	1		
	40	40	712	NE41L		1.5	0.002	1		pata de perfil redondo



DESCRIPCIÓN:

 - PESO NETO



 - VOLUMEN

 - NÚMERO DE PAQUETES

ZIG - ZAG

ILUSTRACIÓN DE PRODUCTO	DIMENSIONES [mm]			REFERENCIA						COMPONENTES
	LARGO	PROFUNDIDAD	ALTURA			kg	m3	pcs		

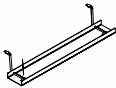
ELEMENTOS DE COMPOSICIÓN

	585	142	712	NL41		2.0	0.063	1		pata de perfil redondo
	460	89	120	E64L		0.5	0.001	1		bandeja horizontal pasacables 09- aluminio
	580	162	123	S69L		1.0	0.015	1		bandeja pasacables 09 - aluminio

DESCRIPCIÓN:

 - PESO NETO

 - VOLUMEN

 - NÚMERO DE PAQUETES